

A-A ( 1 : 1 )

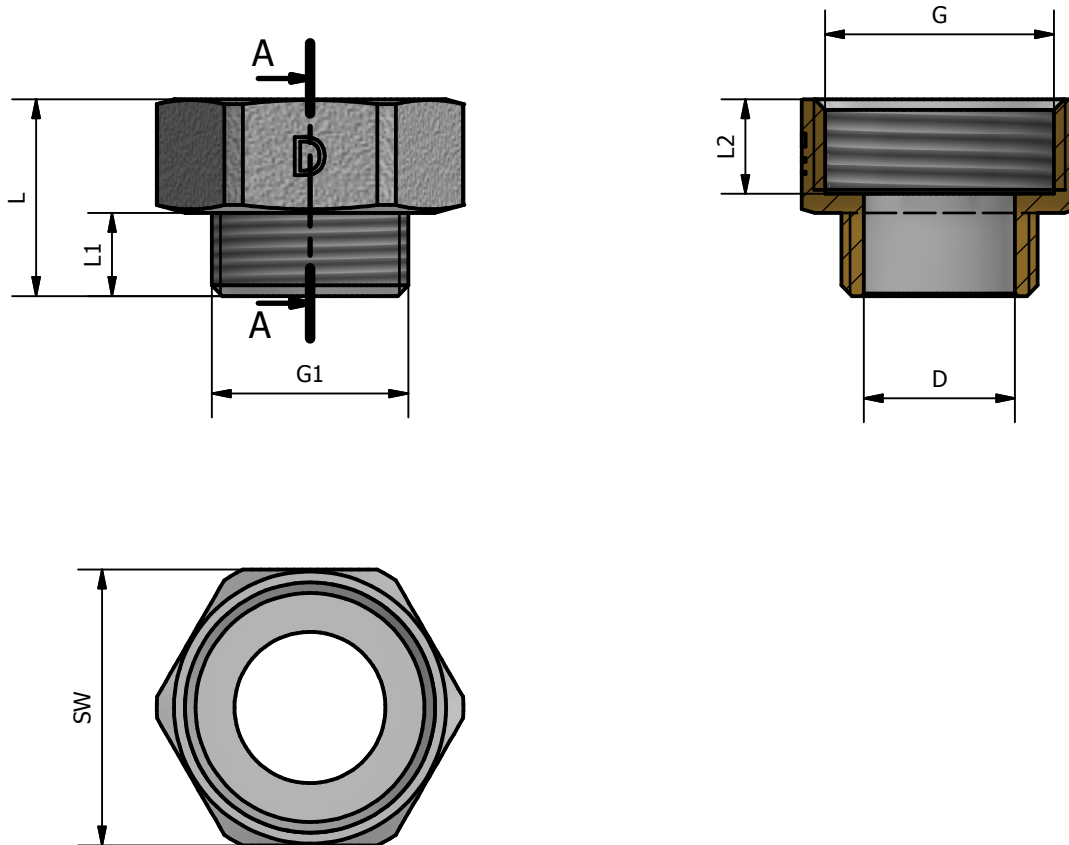

CODE	SIZE	G	G1	L	L1	L2	D	SW
116N 3814	3/8x1/4	3/8	1/4	22	10	10	8	21
116N 1214	1/2x1/4	1/2	1/4	22	10	10	8	23
116N 1238	1/2x3/8	1/2	3/8	22	10	10	11	23,5
116N 3412	3/4x1/2	3/4	1/2	22	10	10	15	29,5
116N 0112	1"x1/2	1"	1/2	25	10	12,5	15	36,5
116N 0134	1"x3/4	1"	3/4	26	11	12,5	20	36,5
116N P412	1"1/4x1/2	1"1/4	1/2	26	10	14	15	46
116N P434	1"1/4x3/4	1"1/4	3/4	27	11	14	18	46
116N P401	1"1/4x1"	1"1/4	1"	28,5	12	14	26	46
116N P201	1"1/2x1"	1"1/2	1"	31,5	16	12,5	26	52
116N P2P4	1"1/2x1"1/4	1"1/2	1"1/4	32	15	14,5	32	52

CONFORMITY	
1)	DM 174 del 6 Aprile 2004
2)	UNI EN ISO 228
3)	UNI EN 1254-4
4)	UNI EN 9227
5)	UNI EN 2819

WORKING PRESSURE MAX from 1/8 to 1"1/4	16 BAR
WORKING PRESSURE MAX from 1"1/2 to 2"	10 BAR
WORKING TEMPERATURE MAX	120°C

00	Prima emissione	Delaini M.	14/02/2015
Rev.	Nota Revisione	Approvatore	Data Approvazione
Toll Gen:	JS13	Stato sup.:	Nichelato
Filetto:	ISO 228	Note tecniche:	
Peso lavorato:	Peso grezzo:	N° stampo:	
Materiale: CW 617N EN12165		Disegnatore: Delaini P.	Data: 14/02/2016
TDM Brass s.r.l via Artigiani, 7-9 25030 Maclodio BS Italy tel +39 030 9972217 fax 030 9787089 www.tdmbrass.it email info@tdmbrass.it			

Codice: 116N

Descrizione: Brass hexagonal reduced extension F/M nickel plated